

Data Sheet



Article number: 604132032050

Description: Taper bored timing belt pulley
HTD 32 8M 50 TL 1615

Measures

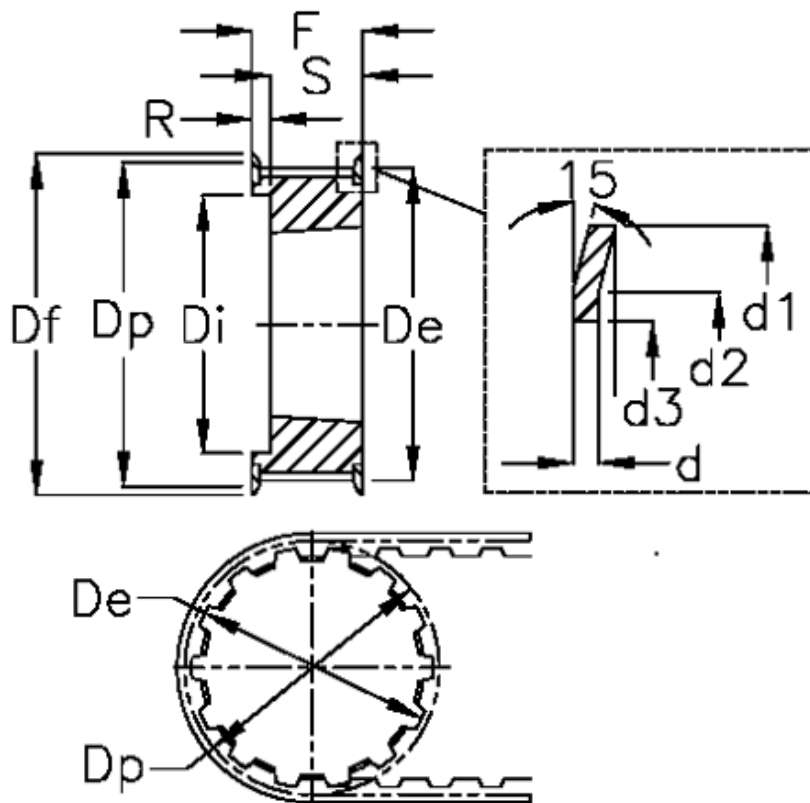

$d = 1.5$	F = 60	Weight = 0.82
$d1 = 87$	Flange type = F30	Width = 50
$d2 = 82.5$	For bushing = 1615	
$d3 = 72$	Max bore = 42	
$De = 80.16$	r = 22	
$Df = 87$	S = 38	
$Di = 62$	Tooth number = 32	
$Dp = 81.49$	Type = 8M	